

ST. PETE EIGHT DEPARTURE

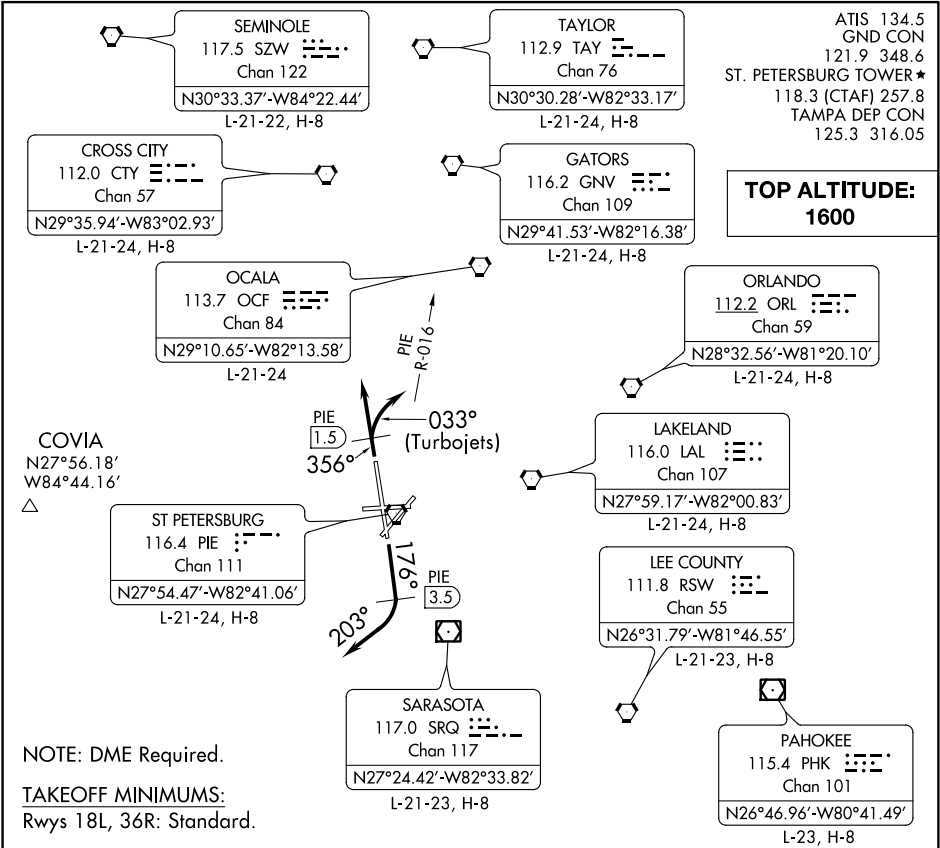

NOTE: DME Required.

TAKEOFF MINIMUMS:

Rwys 18L, 36R: Standard.

TAKEOFF OBSTACLE NOTES

Rwy 18L: Building 689' from DER, 418' right of centerline, 34' AGL/44' MSL. Signs beginning 909' from DER, 98' right of centerline, up to 50' AGL/58' MSL. Poles beginning 970' from DER, 114' right of centerline, up to 51' AGL/58' MSL. Poles beginning 1015' from DER, 103' left of centerline, up to 40' AGL/47' MSL. Sign 1336' from DER, 198' left of centerline, 46' AGL/53' MSL. Tree 2100' from DER, 996' right of centerline, 96' AGL/105' MSL. Antenna on hopper 2583' from DER, 801' right of centerline, 76' AGL/ 89' MSL.

Rwy 36R: Boats beginning 646' from DER, 655' left of centerline, up to 25' MSL.

NOTE: Chart not to scale.

DEPARTURE ROUTE DESCRIPTION

TAKEOFF RWY 18L: Climb heading 176° until PIE VORTAC 3.5 DME, then turn right heading 203° or as assigned. Expect RADAR vectors to filed/assigned route, thence. . . .

TAKEOFF RWY 36R: TURBOJETS climb heading 356° until PIE VORTAC 1.5 DME, then turn right heading 033° to intercept and fly outbound on PIE R-016, thence. . . .

ALL OTHERS fly heading 356° or as assigned. Expect RADAR vectors to filed/assigned route. Thence. . . .

. . . .maintain 1600, expect further clearance to filed altitude 10 minutes after departure.