

# RNAV (GPS)-B

CAMPBELL (C81)

APP CRS	Rwy Idg	N/A
<b>118°</b>	TDZE	N/A
	Apt Elev	<b>788</b>

<p><b>▼</b> Use Chicago O'Hare altimeter setting.                  GPS or RNP-0.3 Required.  <b>▲</b> NA DME/DME-0.3 NA.</p>	<p>MISSED APPROACH: Climb to 2000, then climbing left turn to 2500 direct EDAKE WP and hold.</p>
<p>CHICAGO APP CON  <b>120.55 306.925</b></p>	<p>UNICOM  <b>122.7 (CTAF)</b></p>

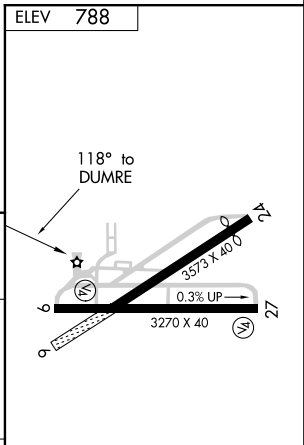
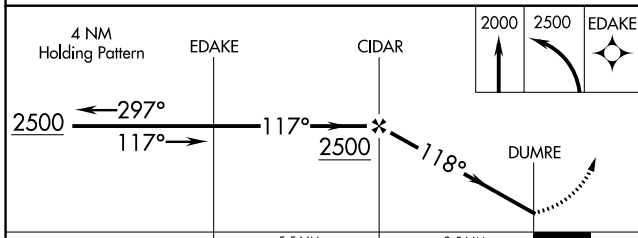
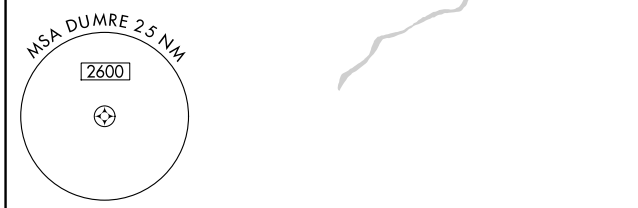
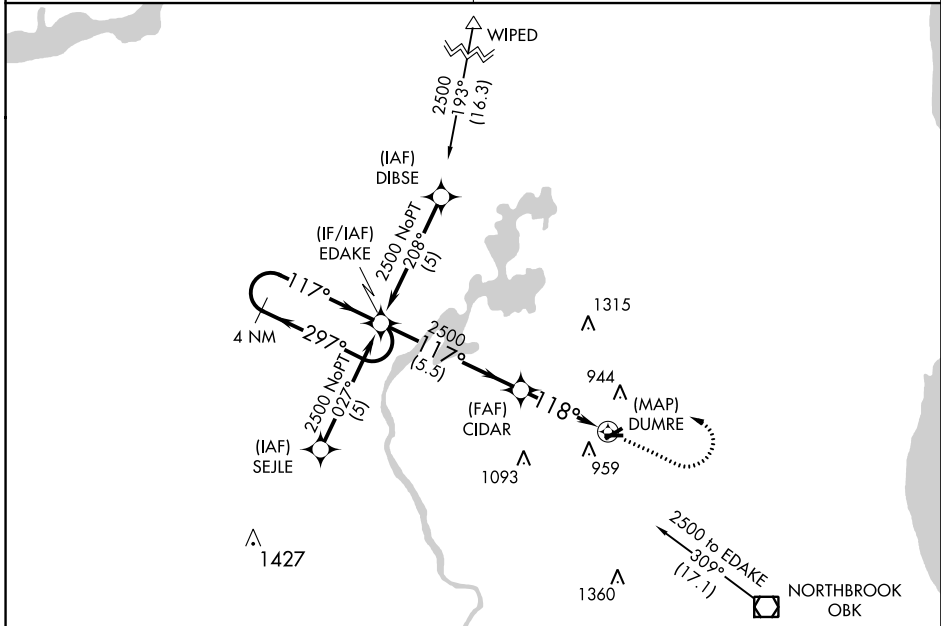

CATEGORY	A	B	C	D
CIRCLING	1380-1 592 (600-1)		1380-1½ 592 (600-1½)	NA

EC-3: 27 APR 2017 to 25 MAY 2017

EC-3: 27 APR 2017 to 25 MAY 2017