

APP CRS 060°	Rwy Idg TDZE Apt Elev	2973 8 8
------------------------	-----------------------------	-------------------------------------

GPS RWY 6
OCEAN CITY MUNI (26N)

▲ NA Use Atlantic City Intl altimeter setting.	MISSED APPROACH: Climbing right turn to 2000 direct SIE VORTAC and hold.
---	--

ATLANTIC CITY APP CON 124.6 327.125	CLNC DEL 133.6	UNICOM 122.7 (CTAF) 0
---	--------------------------	---------------------------------

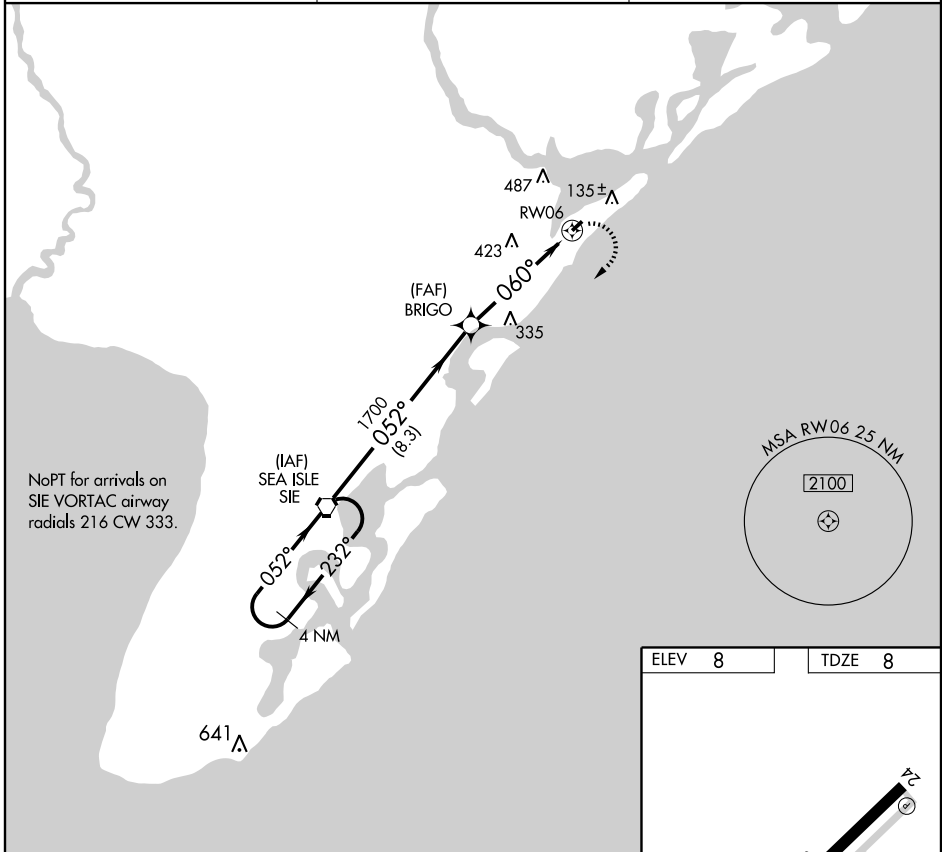

NE-2, 31 MAY 2012 to 28 JUN 2012

NE-2, 31 MAY 2012 to 28 JUN 2012

NoPT for arrivals on SIE VORTAC airway radials 216 CW 333.

ELEV 8	TDZE 8
--------	--------

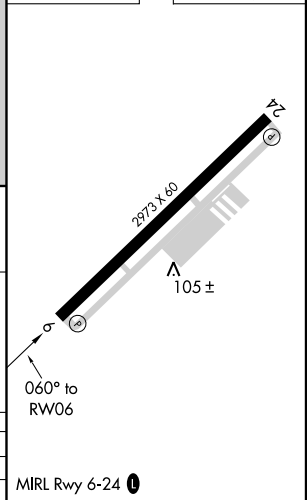
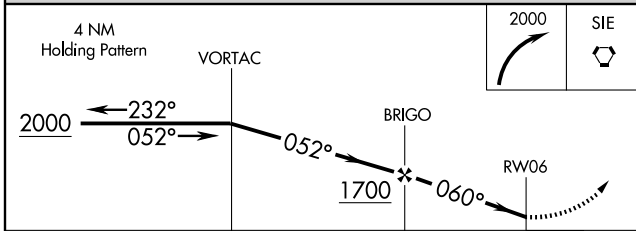

CATEGORY	A	B	C	D
S-6	680-1 672 (700-1)			NA
CIRCLING	680-1 672 (700-1)			NA

VORTAC VCN 115.2 Chan 99	APP CRS 145°	Rwy Idg TDZE Apt Elev	N/A N/A 8
--	------------------------	-----------------------------	--------------------------------------

VOR-A
OCEAN CITY MUNI (26N)

▲ NA Use Atlantic City Intl altimeter setting. MISSED APPROACH: Climbing right turn to 2000 via VCN R-145 to JUDGE Int and hold.

ATLANTIC CITY APP CON 124.6 327.125	CLNC DEL 133.6	UNICOM 122.7 (CTAF) 0
---	--------------------------	---------------------------------

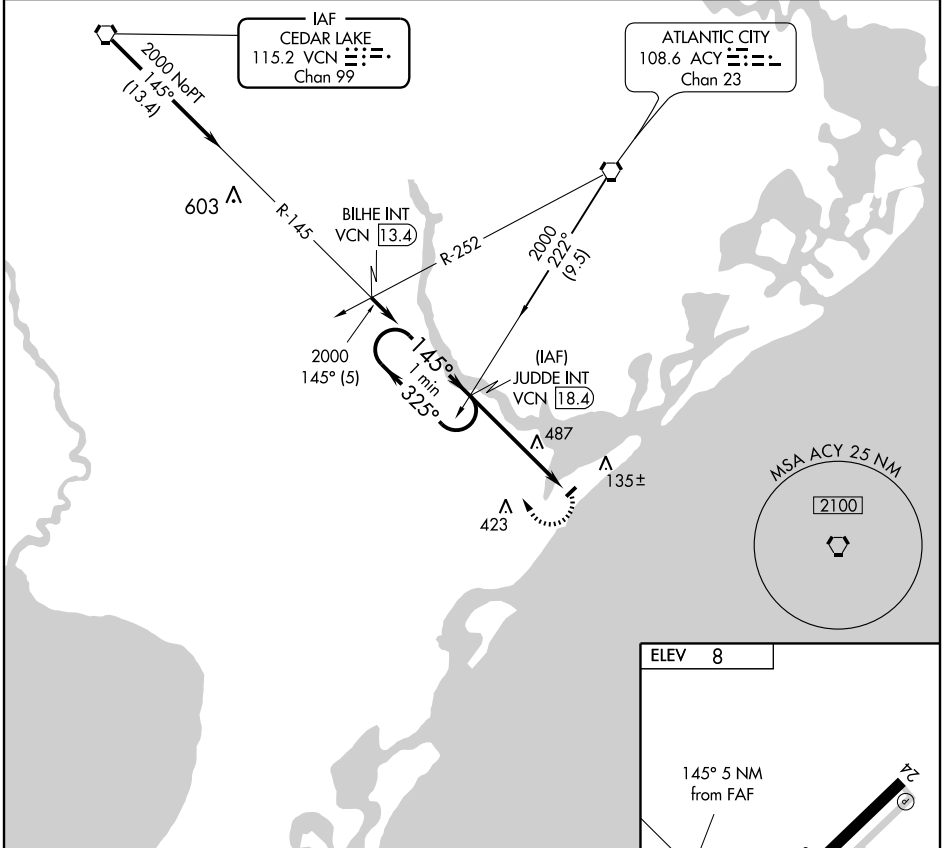

NE-2, 31 MAY 2012 to 28 JUN 2012

NE-2, 31 MAY 2012 to 28 JUN 2012

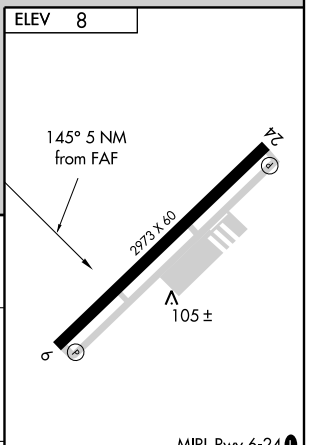
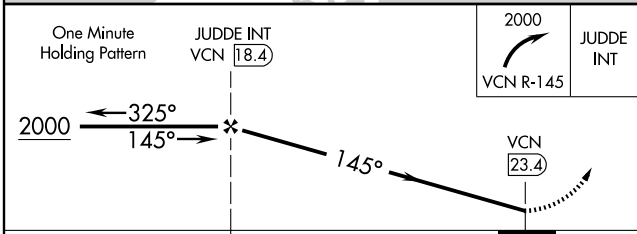

CATEGORY	A	B	C	D	FAF to MAP 5 NM					
CIRCLING	840-1 832 (900-1)	840-1¼ 832 (900-1¼)		NA	Knots	60	90	120	150	180
					Min:Sec	5:00	3:20	2:30	2:00	1:40